

1st Score: _____	2nd Score: _____	3rd Score: _____	_____. ____ <b>Final Score</b>
S & G _____	S & G _____	S & G _____	
Grader: _____	Grader: _____	Grader: _____	

## PLACE LABEL BELOW

Name: \_\_\_\_\_ School: \_\_\_\_\_

SS/ID Number: \_\_\_\_\_ City: \_\_\_\_\_

Grade: 4 5 6 7 8                      Classification: 1A 2A 3A 4A 5A 6A

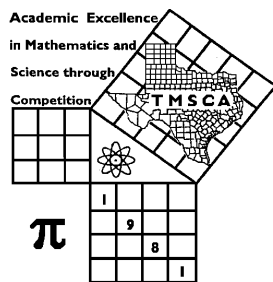

## TMSCA MIDDLE SCHOOL CALCULATOR

TEST # 12 ©

FEBRUARY 16, 2019

### GENERAL DIRECTIONS

- I. About this test:
- You will be given 30 minutes to take this test. There are 80 problems on this test.
  - ALL calculators must be cleared. HP Prime and Casio Prizm calculators are NOT permitted.**
- II. How to write the answers:
- For all problems except stated problem as noted below write three significant digits.
    - Examples (\* means correct, but not recommended)  
 Correct: 12.3, 123, 123.\*, 1.23x10\*, 1.23x10<sup>0\*</sup>, 1.23x10<sup>1</sup>, 1.23x10<sup>01</sup>, .0190, 1.90x10<sup>-2</sup>  
 Incorrect: 12.30, 123.0, 1.23(10)<sup>2</sup>, 1.23·10<sup>2</sup>, 1.230x10<sup>2</sup>, 1.23\*10<sup>2</sup>, 0.19, 1.9x10<sup>-2</sup>, 19.0x10<sup>-3</sup>, 1.90E-02
    - Plus or minus one digit error in the third significant digit is permitted.
  - For stated problems:
    - Except for integer, dollar sign, and significant digit problems, as detailed below, answers to stated problems should be written with three significant digits.
    - Integer problems are indicated by (integer) in the answer blank. Integer problems answers must be exact, no plus or minus one digit, no decimal point or scientific notation.
    - Dollar sign (\$) problems should be answered to the exact cent, but plus or minus one cent error is permitted. The decimal point and cents are required for exact dollar answers.
- III. Some symbols used on the test.
- Angle measure: rad means radians; deg means degrees.
  - Inverse trigonometric functions: arcsin for inverse sine, etc.
  - Special numbers:  $\pi$  for 3.14159 . . . ; e for 2.71828.
  - Logarithms: Log means common (base 10); Ln means natural (base e).
- IV. Scoring:
- All problems answered correctly are worth FIVE points. FOUR points will be deducted for all problems answered incorrectly or skipped before the last problem attempted.

**2018-2019 TMSCA Middle School Calculator Test 12**

1.  $405 - 1010$  ----- 1= \_\_\_\_\_

2.  $6 - 29 - 5$  ----- 2= \_\_\_\_\_

3.  $-15.2 + 11 + 3.7$  ----- 3= \_\_\_\_\_

4.  $\pi - 1 + 3 - 8$  ----- 4= \_\_\_\_\_

5.  $1180 - 1010 - 1960 + 2100$  ----- 5= \_\_\_\_\_

6.  $-35.6 - 58.4 - 217 + 157 + 146$  ----- 6= \_\_\_\_\_

7.  $(0.425 + 0.74 - 0.859) - (0.284 + 1.33)$  ----- 7= \_\_\_\_\_

8.  $(-1.46 - 2.71) + (1.4 - 2.75 - 1.31)$  ----- 8= \_\_\_\_\_

9.  $118 \times 145 \times 679$  ----- 9= \_\_\_\_\_

10.  $1010 \times 147 \times 7720 \times 697$  ----- 10= \_\_\_\_\_

11. The area of a square is 521 square inches. Calculate the perimeter of the square in inches. ----- 11= \_\_\_\_\_ in.

12. Calculate the median of the following list of numbers. Pi, 32,  $4^2$ , 8,  $\sqrt{10}$ , 1.87,  $7^0$ , and  $\sqrt{24}$ . ----- 12= \_\_\_\_\_

13. The sum of three consecutive integers is 456. Calculate the value of the smallest integer. ----- 13= \_\_\_\_\_ INT.

14.  $(12)[29 \times 106 \times 41]$  -----14= \_\_\_\_\_

15.  $(31)[129 \times 64/80]$  -----15= \_\_\_\_\_

16.  $\{(-107)(132 - 102)(277)\} - 4.33 \times 10^5$  -----16= \_\_\_\_\_

17.  $\left[\frac{109}{35}\right] [(152/88) + 0.717]$  -----17= \_\_\_\_\_

18.  $\left[\frac{170/105}{35/58}\right] \{21.4 + 15.4 - 14.4\}$  -----18= \_\_\_\_\_

19.  $\frac{(176/204) + (67/317)}{(0.0437 - 0.0405)}$  -----19= \_\_\_\_\_

20.  $\frac{(313)(0.00147)}{0.00398} (455 - 483)$  -----20= \_\_\_\_\_

21.  $\frac{195}{(247 - 225)} - \frac{(280 - 228)}{220}$  -----21= \_\_\_\_\_

22.  $\left[\frac{1560 + 2190}{5030 - 2010}\right] \left[\frac{4030}{2420}\right]$  -----22= \_\_\_\_\_

23.  $\frac{[-(2650 + 5680)(5790 - 3560)]}{(0.00355/(1.49))}$  -----23= \_\_\_\_\_

24. Brian wanted to go to the parade that was 1.5 miles from his house. He woke up late, so he ran to the parade route at 11 mph. After the parade was over, he walked back home at 4 mph. Calculate how long the round trip took him in hours. -----24= \_\_\_\_\_ hrs.

25. A circle has an area of 425.7 square inches. This circle is inscribed in a square. Calculate the area of the square in square inches. ----25= \_\_\_\_\_ in<sup>2</sup>

26. Randy and Jill are buying appetizers for their party. They have decided on 5 pounds of Tiger Shrimp at \$11.06 per pound, 10 pounds of wings for \$2.78 per pound, 4 vegetable platters at \$9.99 each, and 2 deli platters at \$26.99 each. Calculate the cost of the food for their party. -----26=\$ \_\_\_\_\_

27.  $\frac{(50.9 - 52.4)(1.21 + 0.376)}{(4.17 \times 10^{10})}$  -----27= \_\_\_\_\_

28.  $[665 - (1090 + 411)] + [(0.498)(290 - 869)]$  -----28= \_\_\_\_\_

29.  $\frac{(3.50 \times 10^6) + (3.45 \times 10^6)}{(-0.0038)(0.00236) - 7.60 \times 10^{-6}}$  -----29= \_\_\_\_\_

30.  $\frac{(622 + 536)}{(9.93 \times 10^{10})}$  -----30= \_\_\_\_\_

31.  $\frac{1}{0.0356} + \frac{1}{(0.0423 - 0.0309)}$  -----31= \_\_\_\_\_

32.  $(0.195) \left[ \frac{165}{(2.76 \times 10^{-14})} \right]$  -----32= \_\_\_\_\_

33.  $1/(0.0016 - 5.84 \times 10^{-4}) - 1/(4.18 \times 10^{-4})$  -----33= \_\_\_\_\_

34.  $\left[ \frac{1/103}{1/222} \right] [1.32 \times 10^6]$  -----34= \_\_\_\_\_

35. The area of a rectangle is 264 square feet. The length is 10 more than the width. Calculate the length of the rectangle in feet. -----35= \_\_\_\_\_ ft.

36. Sally completed task A in a speedy 32 minutes. Tommy is slower and completes task A in 45 minutes. Calculate the time it would take to complete task A if they worked together. -----36= \_\_\_\_\_ min.

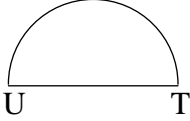
RECTANGLE	SEMICIRCLE
	
Perimeter = 557.6	Arc UT = 5213
221.8	Area = ?
Diagonal = ?	38= _____
37= _____	

39.  $(33.2 + 34.2)^2(83 + 25.7)^2$  -----39= \_\_\_\_\_

40.  $\sqrt[3]{\frac{0.182 + 1.4}{4550 - 2780}}$  -----40= \_\_\_\_\_

41.  $(81.1 + 79.9 + 88.8)^2(0.108 + 0.123)^2$  -----41= \_\_\_\_\_

42.  $(79500)\sqrt{160 + 138 + 135}$  -----42= \_\_\_\_\_

43.  $\sqrt{(11.5/22.1) + 0.442 - 0.323}$  -----43= \_\_\_\_\_

44.  $\sqrt{1350 - 1330 + 404} - \sqrt{214}$  -----44= \_\_\_\_\_

45.  $(239)\sqrt[3]{71.9 + 205 - 74.9}$  -----45= \_\_\_\_\_

46.  $\sqrt{0.736 - 1140/1940} + 1/\sqrt{42.8 + 9.05}$  -----46= \_\_\_\_\_

47. The height of an equilateral triangle is 57218 inches. Calculate the length of one of the sides of the triangle in inches. -----47= \_\_\_\_\_ in.

48. Calculate  $469^{-964}$ . -----48= \_\_\_\_\_

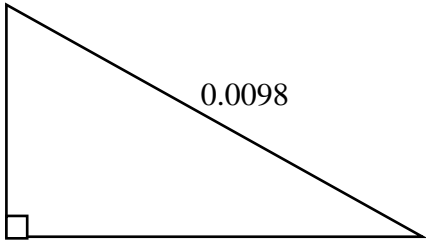
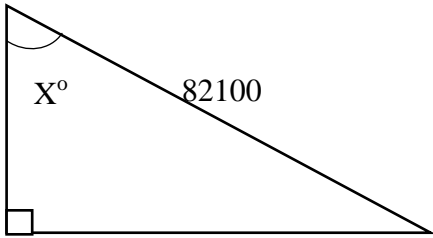
<p style="text-align: center;"><b>RIGHT TRIANGLE</b></p>  <p style="text-align: center;">Perimeter = ?</p> <p>49= _____</p>	<p style="text-align: center;"><b>RIGHT TRIANGLE</b></p>  <p style="text-align: center;"><math>X^\circ = ?</math></p> <p>50= _____</p>
--	--

51.  $\left[ \frac{62.9 - 33.5 + \sqrt{18100/39.2}}{-13.5 + 128} \right]^4$  -----51= \_\_\_\_\_

52.  $\frac{(24.6 + 8.47 - 23.6)^3}{\sqrt{1290 + 2640 + 1260}}$  -----52= \_\_\_\_\_

53.  $\left[ \frac{3840 + 8420 + \sqrt{1.47 \times 10^8 + 2.91 \times 10^7}}{50.7/11.8} \right]^2$  -----53= \_\_\_\_\_

54.  $(44.3)^2 \sqrt{(186)/(112)} - (937 + 563)$  -----54= \_\_\_\_\_

55.  $681 + \sqrt{(845)(756)} - (205 + 885)$  -----55= \_\_\_\_\_

56.  $\sqrt{\frac{1/(189 - 145)}{(168)(31.7 + 26.5)^4}}$  -----56= \_\_\_\_\_

57.  $\sqrt{\frac{1/(2020 - 643)}{(309)(7.52 + 32.9)^{-6}}}$  -----57= \_\_\_\_\_

58.  $(\text{deg}) \tan(832^\circ) + (56.5/46.4)$  -----58= \_\_\_\_\_

59. Calculate how many arrangements of letters using 3 consonants and 2 vowels can be formed out of 7 consonants and 4 vowels. ---59= \_\_\_\_\_ INT.

60. A 20 foot by 30 foot pool is surrounded by a deck of uniform width. The area of the deck is equal to the area of the pool. Calculate the width of the deck in feet. -----60= \_\_\_\_\_ ft.

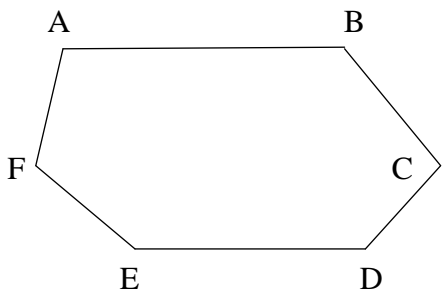
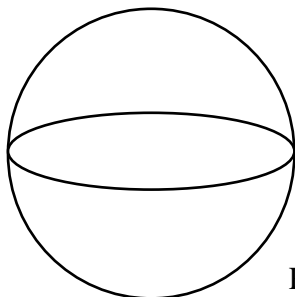
<p style="text-align: center;"><b>HEXAGON</b></p>  <p>             Angle A = <math>5x + 4</math>              Angle B = <math>6x + 8</math>              Angle C = <math>4x + 22</math>              Angle D = <math>7x - 8</math>              Angle E = <math>6.2x</math>              Angle F = <math>7x - 10</math> </p> <p style="text-align: center;">Smallest Angle = ?°</p> <p>61= _____</p>	<p style="text-align: center;"><b>SPHERE</b></p>  <p style="text-align: right;">Diameter = 72.55</p> <p style="text-align: right;">Ratio of Volume to Surface Area = ?</p> <p>62= _____</p>
---	---

63.  $\frac{12! + 11!}{14!}$  ----- 63= \_\_\_\_\_

64.  $(4.03 \times 10^5 - 3.31 \times 10^5)^4 (2.88 \times 10^6)$  ----- 64= \_\_\_\_\_

65. (deg)  $(33.6 - 31.2) \cos(42.1^\circ)$  ----- 65= \_\_\_\_\_

66. (deg)  $[52.1] \tan(8.18^\circ - 8.15^\circ)$  ----- 66= \_\_\_\_\_

67. (deg)  $\cos(77.1^\circ - 37.3^\circ) + 0.233$  ----- 67= \_\_\_\_\_

68. (deg)  $\frac{\sin(20.6^\circ) - \tan(20.6^\circ)}{\sin(20.6^\circ)}$  ----- 68= \_\_\_\_\_

69. (deg)  $\frac{\sin(38^\circ)}{168 + 241}$  ----- 69= \_\_\_\_\_

70.  $(1230 - 1070)^{0.527} - 0.113$  ----- 70= \_\_\_\_\_

71. If it takes 14 hrs for a faucet with a flow of 18 liters per minute to fill a pool with water. Calculate the time it will take if the flow is reduced to 10 liters per minute. ----- 71= \_\_\_\_\_ hrs.

72. TMSC is a square. A is the midpoint of MS and B is the midpoint of TM. A point is selected at random in the square. Calculate the probability that it lies in the triangle BMA. ----- 72= \_\_\_\_\_

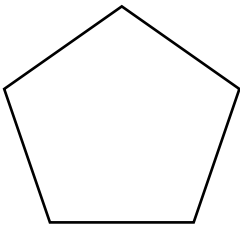
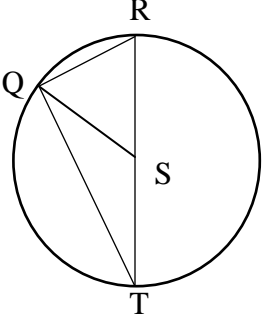
REGULAR PENTAGON	CIRCLE S AND TRIANGLE
	
Area = 1521	QS = 5.25 QR = 6.71
Perimeter = ?	QT = ?
73= _____	74= _____

75.  $\ln\left[\frac{112 + 172 + 125}{101 + 94.5 - 78.1}\right]$  -----75= \_\_\_\_\_

76.  $\frac{(2.1)^{0.213}(6.39)^{0.208}}{(5.07 - 4.71)^{-10}}$  -----76= \_\_\_\_\_

77.  $2\log\sqrt{\frac{(2.82)(\pi)}{0.224 + 0.532}}$  -----77= \_\_\_\_\_

78.  $\ln\left[\frac{15.7 + 34.1 + 23.9}{1820 - 376 - 324}\right]$  -----78= \_\_\_\_\_

79.  $1 + 3 + 5 + \dots + 805$  -----79= \_\_\_\_\_

80.  $1 + 0.56 + (0.56)^2 + \frac{(0.56)^4}{8} - \frac{(0.56)^5}{15}$  -----80= \_\_\_\_\_



## 2018-2019 TMSCA Middle School Calculator Test 12 Answer Key

Page 1	Page 2	Page 3	Page 4
1 = -605 = $-6.05 \times 10^2$	14 = $1.51 \times 10^6$	27 = $-5.71 \times 10^{-11}$	39 = $5.37 \times 10^7$
2 = -28.0 = $-2.80 \times 10^1$	15 = 3200 = $3.20 \times 10^3$	28 = -1120 = $-1.12 \times 10^3$	40 = 0.0963 = $9.63 \times 10^{-2}$
3 = -0.500 = $-5.00 \times 10^{-1}$	16 = $-1.32 \times 10^6$	29 = $-4.19 \times 10^{11}$	41 = 3330 = $3.33 \times 10^3$
4 = -2.86 = $-2.86 \times 10^0$	17 = 7.61 = $7.61 \times 10^0$	30 = $1.17 \times 10^{-8}$	42 = $1.65 \times 10^6$
5 = 310 = $3.10 \times 10^2$	18 = 60.1 = $6.01 \times 10^1$	31 = 116 = $1.16 \times 10^2$	43 = 0.800 = $8.00 \times 10^{-1}$
6 = -8.00 = $-8.00 \times 10^0$	19 = 336 = $3.36 \times 10^2$	32 = $1.17 \times 10^{15}$	44 = 5.96 = $5.96 \times 10^0$
7 = -1.31 = $-1.31 \times 10^0$	20 = -3240 = $-3.24 \times 10^3$	33 = -1410 = $-1.41 \times 10^3$	45 = 1400 = $1.40 \times 10^3$
8 = -6.83 = $-6.83 \times 10^0$	21 = 8.63 = $8.63 \times 10^0$	34 = $2.85 \times 10^6$	46 = 0.524 = $5.24 \times 10^{-1}$
9 = $1.16 \times 10^7$	22 = 2.07 = $2.07 \times 10^0$		
10 = $7.99 \times 10^{11}$	23 = $-7.80 \times 10^9$	35 = 22.0 = $2.20 \times 10^1$	47 = 66100 = $6.61 \times 10^4$
11 = 91.3 = $9.13 \times 10^1$	24 = 0.511 = $5.11 \times 10^{-1}$	36 = 18.7 = $1.87 \times 10^1$	48 = $9.76 \times 10^{-2576}$
12 = 4.03 = $4.03 \times 10^0$	25 = 542 = $5.42 \times 10^2$	37 = 229 = $2.29 \times 10^2$	49 = 0.0233 = $2.33 \times 10^{-2}$
13 = 151 INT.	26 = \$177.04	38 = 4330000 = $4.33 \times 10^6$	50 = 62.6 = $6.26 \times 10^1$

## 2018-2019 TMSCA Middle School Calculator Test 12 Answer Key

### Page 5

$$51 = 0.0390$$
$$= 3.90 \times 10^{-2}$$

$$52 = 11.8$$
$$= 1.18 \times 10^1$$

$$53 = 3.53 \times 10^7$$

$$54 = 1030$$
$$= 1.03 \times 10^3$$

$$55 = 390$$
$$= 3.90 \times 10^2$$

$$56 = 3.43 \times 10^{-6}$$

$$57 = 101$$
$$= 1.01 \times 10^2$$

$$58 = -1.26$$
$$= -1.26 \times 10^0$$

$$59 = 2520 \text{ INT.}$$

$$60 = 5.00$$
$$= 5.00 \times 10^0$$

### Page 6

$$61 = 102$$
$$= 1.02 \times 10^2$$

$$62 = 12.1$$
$$= 1.21 \times 10^1$$

$$63 = 0.00595$$
$$= 5.95 \times 10^{-3}$$

$$64 = 7.74 \times 10^{25}$$

$$65 = 1.78$$
$$= 1.78 \times 10^0$$

$$66 = 0.0273$$
$$= 2.73 \times 10^{-2}$$

$$67 = 1.00$$
$$= 1.00 \times 10^0$$

$$68 = -0.0683$$
$$= -6.83 \times 10^{-2}$$

$$69 = 0.00151$$
$$= 1.51 \times 10^{-3}$$

$$70 = 8.18$$
$$= 8.18 \times 10^0$$

$$71 = 25.2$$
$$= 2.52 \times 10^1$$

$$72 = 0.125$$
$$= 1.25 \times 10^{-1}$$

### Page 7

$$73 = 149$$
$$= 1.49 \times 10^2$$

$$74 = 8.08$$
$$= 8.08 \times 10^0$$

$$75 = 1.25$$
$$= 1.25 \times 10^0$$

$$76 = 6.30 \times 10^{-5}$$

$$77 = 1.07$$
$$= 1.07 \times 10^0$$

$$78 = -2.72$$
$$= -2.72 \times 10^0$$

$$79 = 162000$$
$$= 1.62 \times 10^5$$

$$80 = 1.88$$
$$= 1.88 \times 10^0$$

11.  $4(\sqrt{521})$

12. The numbers in order are:

$7^0, 1.87, \pi, \sqrt{10}, \sqrt{24}, 8, 4^2, 32$

Since there are 8 numbers, average the two in the middle.

$$\frac{\sqrt{10} + \sqrt{24}}{2}$$

13. The middle integer is

$\frac{456}{3} = 152$ . Add 1 to get the largest integer.

24.  $time = \frac{distance}{rate}$

$$\frac{1.5}{11} + \frac{1.5}{4}$$

25. diameter = side of square

$$\pi r^2 = 425.7$$

$$r = \sqrt{\frac{425.7}{\pi}}; d = 2\left(\sqrt{\frac{425.7}{\pi}}\right)$$

$$A = d^2 = \left[2\left(\sqrt{\frac{425.7}{\pi}}\right)\right]^2$$

26.

$$5(11.06) + 10(2.78) + 4(9.99) + 2(26.99)$$

35.  $w = width; w + 10 = length$

$$w(w + 10) = 264$$

$$w^2 + 10w - 264 = 0$$

Use the quadratic formula or factor to find the width. 12.0. Therefore the length is 22.0.

36.  $\frac{32(45)}{32+45}$

37.  $width = \frac{557.6 - 221.8(2)}{2} = 57$   
 $diagonal = \sqrt{57^2 + 221.8^2}$

38.  $\pi r = 5213$  so  $r = \frac{5213}{\pi}$   
 $Area = \frac{\pi r^2}{2} = \frac{\pi \left(\frac{5213}{\pi}\right)^2}{2}$

47.  $2\left(\frac{57218}{\sqrt{3}}\right)$

48.  $469^{-964}$

*(Look at the digits to the left of the decimal. This gives -2575 for the exponent. Write down -2575.)*  
 Punch

-2575

*(This gives 9.76 E-1) Since it says E-1, you have to add -1 to -2575. This is done on the HP RPN calculator.*

49.

$$\sqrt{.0098^2 - .0051^2} + .0051 + .0098$$

50.  $\frac{\cos x}{1} = \frac{37720}{82100}$   
 $\text{acos or } \cos^{-1}\left(\frac{37720}{82100}\right)$

59.  $\left(\frac{7!}{(7-3)!}\right) \left(\frac{4!}{(4-2)!}\right)$

60. Deck width = x  
 Dimensions of outside of deck =  $(20+2x)$  and  $(30+2x)$   
 $\frac{1}{2}(20 + 2x)(30 + 2x) = 600$   
 $(20 + 2x)(30 + 2x) = 1200$

60. contd.

$4x^2 + 100x - 600 = 0$ .  
 Use quadratic formula or factor to find x.

61. The sum of the angles in a hexagon is  $180(6-2) = 720^\circ$ .  
 The sum of the given angles is  $35.2x + 16$ .

Eq:  $35.2x + 16 = 720$   
 $x = 20$ . Substitute 20 for x in the angles and Angle C is the smallest at  $102^\circ$ .

62.  $\frac{V}{SA} = \frac{\frac{4}{3}\pi r^3}{4\pi r^2} = \frac{1}{3}r$   
 $diameter = 72.55$   
 $radius = \frac{72.55}{2}$

Ratio is  $\frac{1}{3}\left(\frac{72.55}{2}\right)$

71.  $14(18) = 10x$   
 $x = \frac{14(18)}{10}$

72. Triangle BMA is 1/8 of the square. You can see this if you connect all midpoints to each other.

73.  $\frac{Perimeter^2}{\left(\tan \frac{180}{5}\right)(4)(5)} = 1521$   
 $P = \sqrt{1521 \left[\left(\tan \frac{180}{5}\right)(4)(5)\right]}$

74. Since  $\overline{RST}$  is a diameter, triangle QRT is a right triangle.  
 $\overline{RT} = 5.25(2)$   
 $\overline{QR} = 6.71$   
 $\overline{QT} = \sqrt{[(5.25)(2)]^2 - 6.71^2}$